



Scout  
Konstantin Grcic  
2026

**vitra.**





# Scout

Konstantin Grcic, 2026



Scout is a family of mobile and stationary work and meeting tables that can be arranged into flexible configurations to suit daily needs and dynamic use – and then stowed away to save space when no longer required. The individual models serve different purposes and can be used in a variety of areas that require adaptable horizontal surfaces – such as workshops, for meetings, training courses or corporate learning environments, project settings, team hubs and much more.

The distinctive, robustly dimensioned tubular steel frames form Scout's defining structural and aesthetic feature. They ensure stability and a sustainable use of materials. Depending on the model, the frames also function as attachment points for the mechanical height adjustment components, and in combination with a range of ingeniously simple accessories and screens, they offer options for personalisation and provide a partitioning effect and sense of privacy.

The three table models on castors enable agile working and also open up new areas of application – even in confined spaces, thanks to the compact Scout Work Mobile and Scout Sprint models. A stationary work table and a meeting table complete the family, covering almost every potential purpose and location.

1–5 Scout  
6–15 Scout Work  
16–25 Scout Work Mobile  
26–31 Scout Sprint  
32–37 Scout Summit

38–45 Scout Meet  
46–59 Moodboards  
60 Sustainable quality  
61 Colours and materials  
62–63 Dimensions



## **Konstantin Grcic**

Konstantin Grcic was trained as a cabinetmaker at Parnham College in Dorset before studying industrial design at the Royal College of Art in London. In 1991 he set up his own practice, Konstantin Grcic Design. The Vitra Design Museum devoted a monographic exhibition to Grcic and his work in 2014.

# Scout Work





# Scout Work

Konstantin Grcic, 2026



Scout Work desk is a functional and original alternative to traditional classic height-adjustable desks on columns. The striking tubular steel frame extends above the table top, encircling the work surface. The desk can be seamlessly fitted with screens, but even without them, it provides an enhanced sense of privacy for the user. The table top's ingenious height adjustment and tilting features work without electricity.

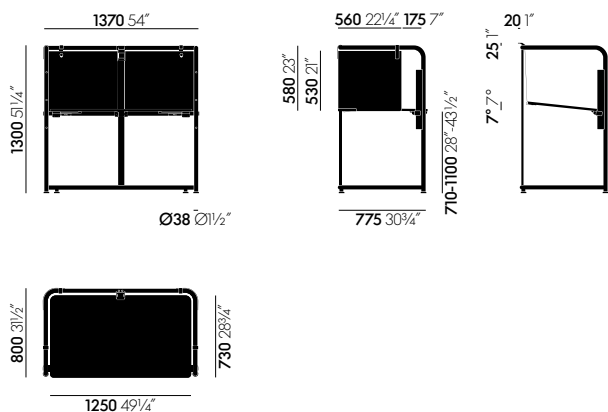

## Scout Work

## Height adjustment



Using the simple release levers, the table top can be vertically adjusted at 2 cm increments from 72 to 110 cm in height – without any source of electricity. Maximum load during height adjustment: 15 kg.

## Table top with tilt function

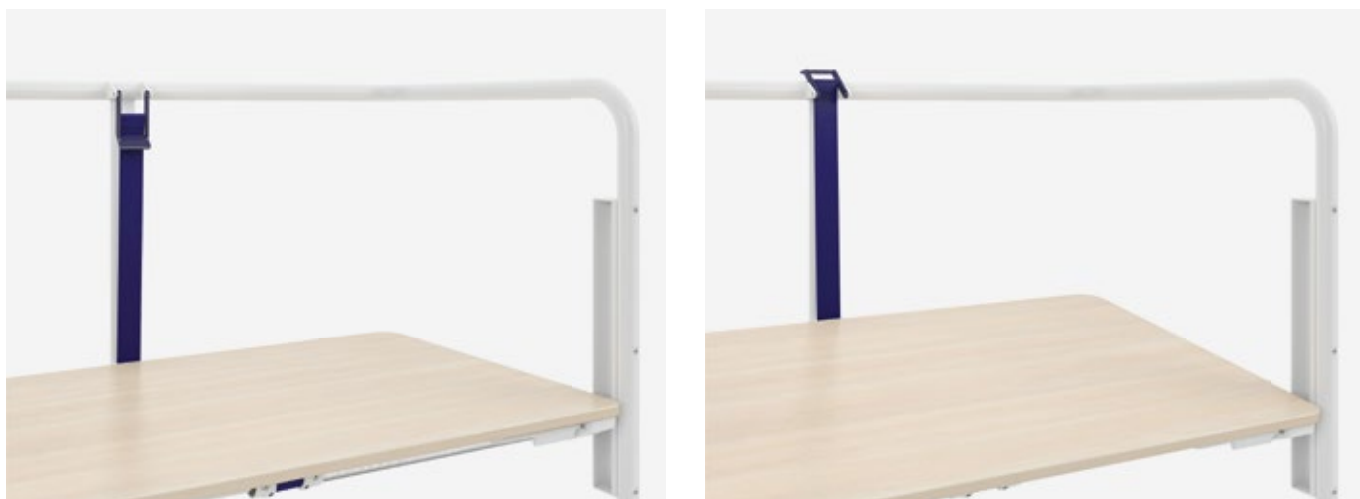

Simply adjust the lever on the strap to tilt the table top slightly (by 7 degrees) when needed.

# Screen



Screen made of polyester fleece with recycled content or natural fibre (hemp). The screen is mounted using the hooks supplied. No other tools are necessary.

The screen offers two-way visual and acoustic privacy and promotes focus and concentrated work. Without a screen, the frame tube defines personal space while providing a comfortable support for colleagues to lean on during desktalk conversations. The frame can be customised with accessories.

# Accessories



The pinboard is hooked onto the frame without the need for tools and can be used to pin up papers and notes, while also serving as a compact privacy screen.

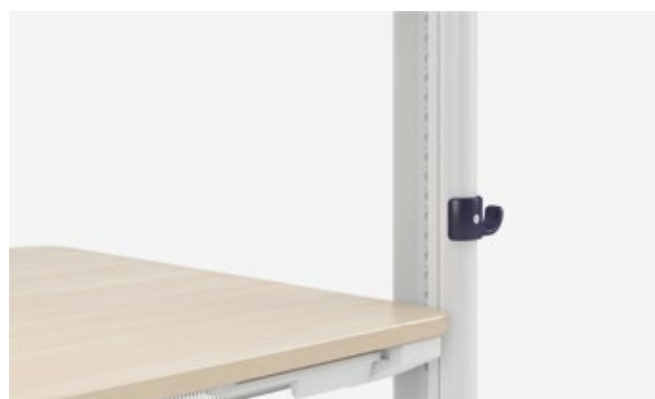

The side hook is screwed directly to the frame tube and serves as a handy spot to hang up bags and other items. It can be retrofitted at any time and is always positioned on the right-hand side.

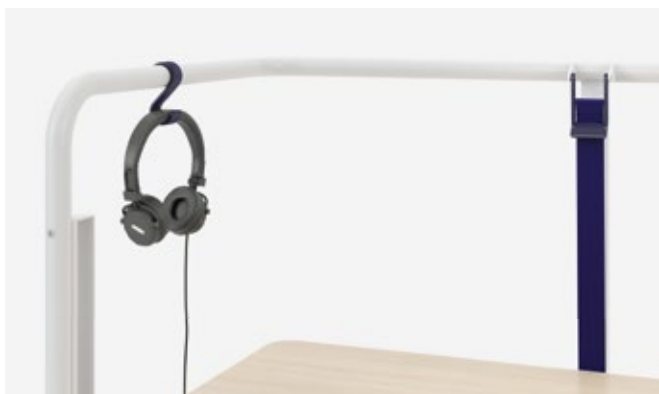

The S-hook fits frames with a diameter of 35 or 38 mm and clips directly onto the frame, providing a convenient place to hang jackets, headphones and more.



**Ampi desk socket**, with power and USB-A and USB-C charging options

**No image available**

Alternatively, **mobile battery products** can provide a flexible solution. They offer power and USB-A/USB-C charging depending on the model, and can be returned to a charging station when not in use.









# Scout Work Mobile





# Scout Work Mobile

Konstantin Grcic, 2026



The compact, height-adjustable Scout Work Mobile table with castors offers the utmost flexibility to both individuals and teams. It can be used on its own or combined to form systems for collaborative working, thanks to its trapezoidal table top. When not in use, the table tops can be folded up and the bases can be nested to save space.

The tubular steel frame extends above the table top, wrapping around the work surface to create a defined, enclosed space – even without screens or accessories. Intended for temporary usage scenarios, Scout Work Mobile does not come with power and data connections.

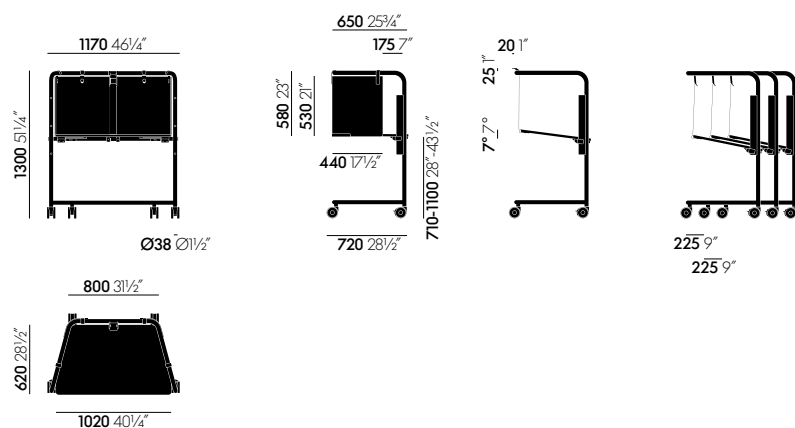

## Scout Work Mobile

## Height adjustment



### Manual height adjustment

Using the simple release levers, the table top can be vertically adjusted at 2 cm increments from 72 to 110 cm in height – without any source of electricity. Maximum load during height adjustment: 15 kg.

## On castors



Four castors with a 10 cm diameter to ensure smooth, frictionless movement; front two with locking mechanism.



The screen offers two-way visual and acoustic privacy and promotes focus and concentrated work. Without a screen, the frame tube defines personal space while providing a comfortable support for colleagues to lean on during desktalk conversations. The frame can be customised with accessories.

## Accessories



The pinboard is hooked onto the frame without the need for tools and can be used to pin up papers and notes, while also serving as a compact privacy screen.



The S-hook fits frames measuring 35 or 38 mm in diameter and clips directly onto the frame, providing a convenient place to hang jackets, headphones and more.



The side hook is screwed directly to the frame tube and serves as a handy spot to hang up bags and other items. It can be retrofitted at any time and is always positioned on the right-hand side.

## Table top with tilt function



Simply adjust the lever on the strap to tilt the table top slightly (by 7 degrees) when needed.

## Space-saving storage



When not in use, the tables can be compactly fitted together, or 'nested'. To do so, the table top must be set to the lowest position, the nesting position. Each nested Scout Work Mobile occupies just 23 cm of additional space, and one person can move up to 5 tables at once.

## Power connections



**Ampi desktop socket**, with power and USB-A and USB-C charging options

### **No image available**

Alternatively, **mobile battery products** can provide a flexible solution. They offer power and USB-A/USB-C charging depending on the model, and can be returned to a charging station when not in use.



The compact Scout Work Mobile tables can be grouped in any configuration as needed

# Scout Work Mobile





# Scout Sprint





# Scout Sprint

Konstantin Grcic, 2026



Scout Sprint is a small table on castors, suitable for a single-person workspace. It is available in a standard seating-height version and as Scout Sprint High in standing height. The Scout Sprint table tops can be easily folded down, while the base units seamlessly nest into one another for efficient space-saving.

Scout Sprint is a compact desk solution conceived for maximum flexibility, perfect as a lectern, training table, workshop companion and more. The addition of a screen in a hanging or upright position can provide a degree of privacy for the user.

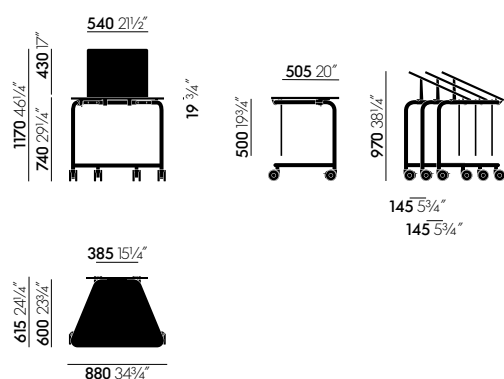

## Scout Sprint

## Standing or sitting

Scout Sprint is available in two versions: a standard seating-height model (74 cm) or the taller standing-height variant Scout Sprint High (105 cm).



## On castors

Four castors with a 10 cm diameter to ensure smooth, frictionless movement; front two with locking mechanism.

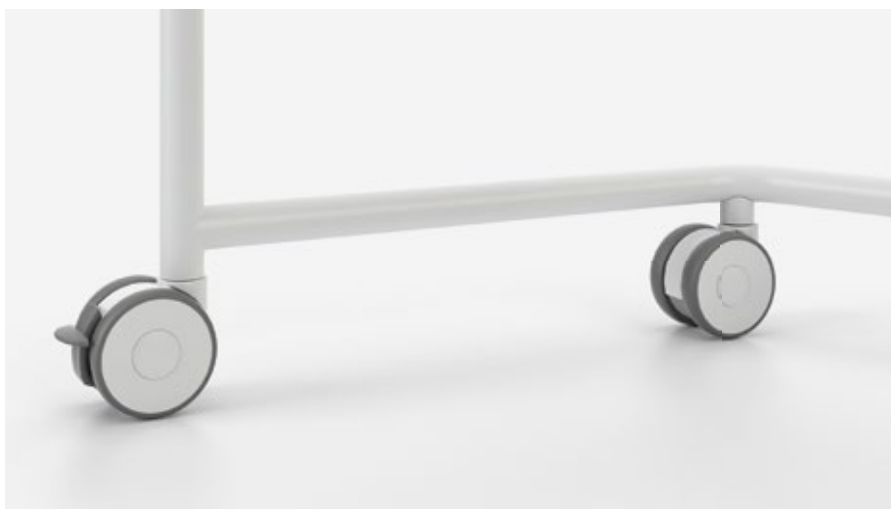

## Space-saving storage

When the table top is lifted, it automatically springs into the nesting position, allowing the tables to be compactly fitted together for efficient storage. Each Scout Sprint takes up just 14.5 cm of additional space. An unlimited number can be nested together, and one person can easily move up to 5 tables at once.

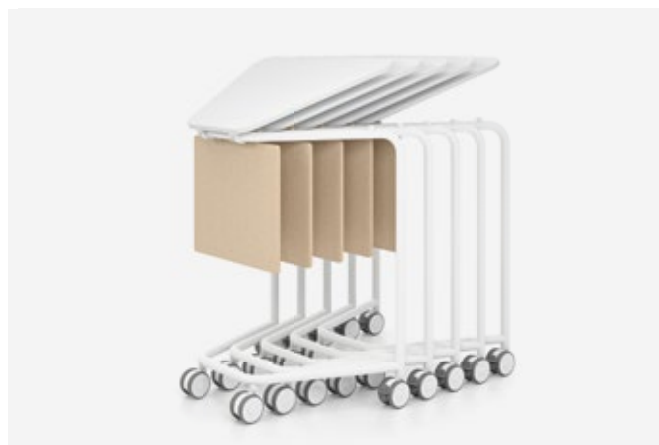

## Screen

The screen clips onto the frame without the need for tools and serves as either a modesty panel or privacy shield. In both positions, it is held in place by magnets.



## Power connections

If power connections are required, these can be made available directly on the table top via a feed cable, a loose socket such as Ampii or a rechargeable battery – with simplicity as the central focus to maintain Scout Sprint's flexibility.



## Accessories

The S-hook can be optionally used to hang accessories or bags.



Scout Sprint compactly nested for efficient storage, ready for future use



Scout Sprint with screen used as a privacy shield to signal focus and concentration



Scout Sprint in front-facing layout, such as for training or learning sessions

# Scout Summit





# Scout Summit

Konstantin Grcic, 2026



Thanks to the unique trapezoidal shape of the design, alongside the castors, the Scout Summit Workshop and the Scout Summit Meeting tables can be easily combined into a variety of table configurations. Scout Summit is ideal for dynamic training sessions, meetings, workshops and much more – and when no longer in use, the tables can be nested together and stowed away to save space.

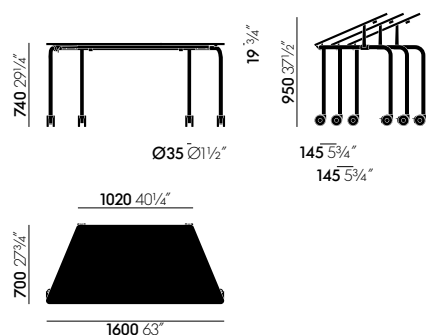

## Scout Summit

## Trapezoidal shape



Thanks to its trapezoidal shape, Scout Summit can be grouped in a wide variety of configurations. The legs are positioned to ensure ample space for users on all sides.

## On castors

Four castors with a 10 cm diameter to ensure smooth, frictionless movement; front two with locking mechanism.



## Space-saving storage



When the table top is lifted, it automatically springs into the nesting position, allowing the tables to be compactly fitted together for efficient storage. Each Scout Summit takes up just 14.5 cm of additional space. An unlimited number can be nested together, and one person can easily move up to 5 tables at once.



Scout Summit compactly nested for efficient storage, ready for future use

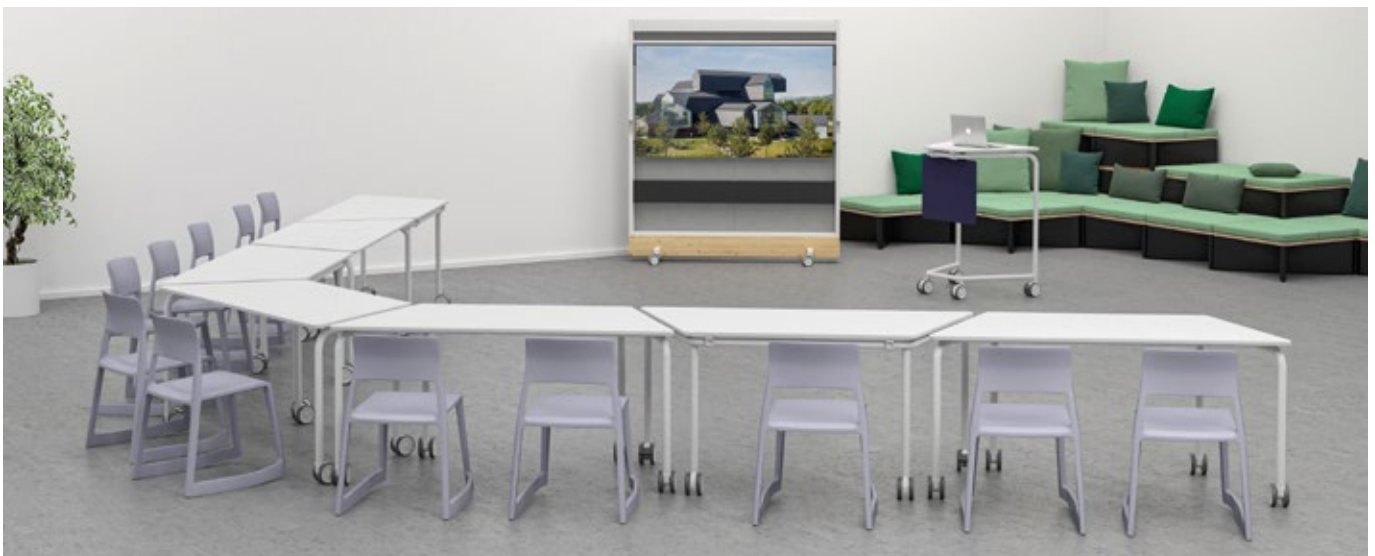

Scout Summit in a staggered V-shaped formation to ensure clear forward-facing views. Scout Sprint High used as a lectern



A pair of Scout Summit tables joined together along their long edges form a hexagon with seating for up to 6 people

# Combination options

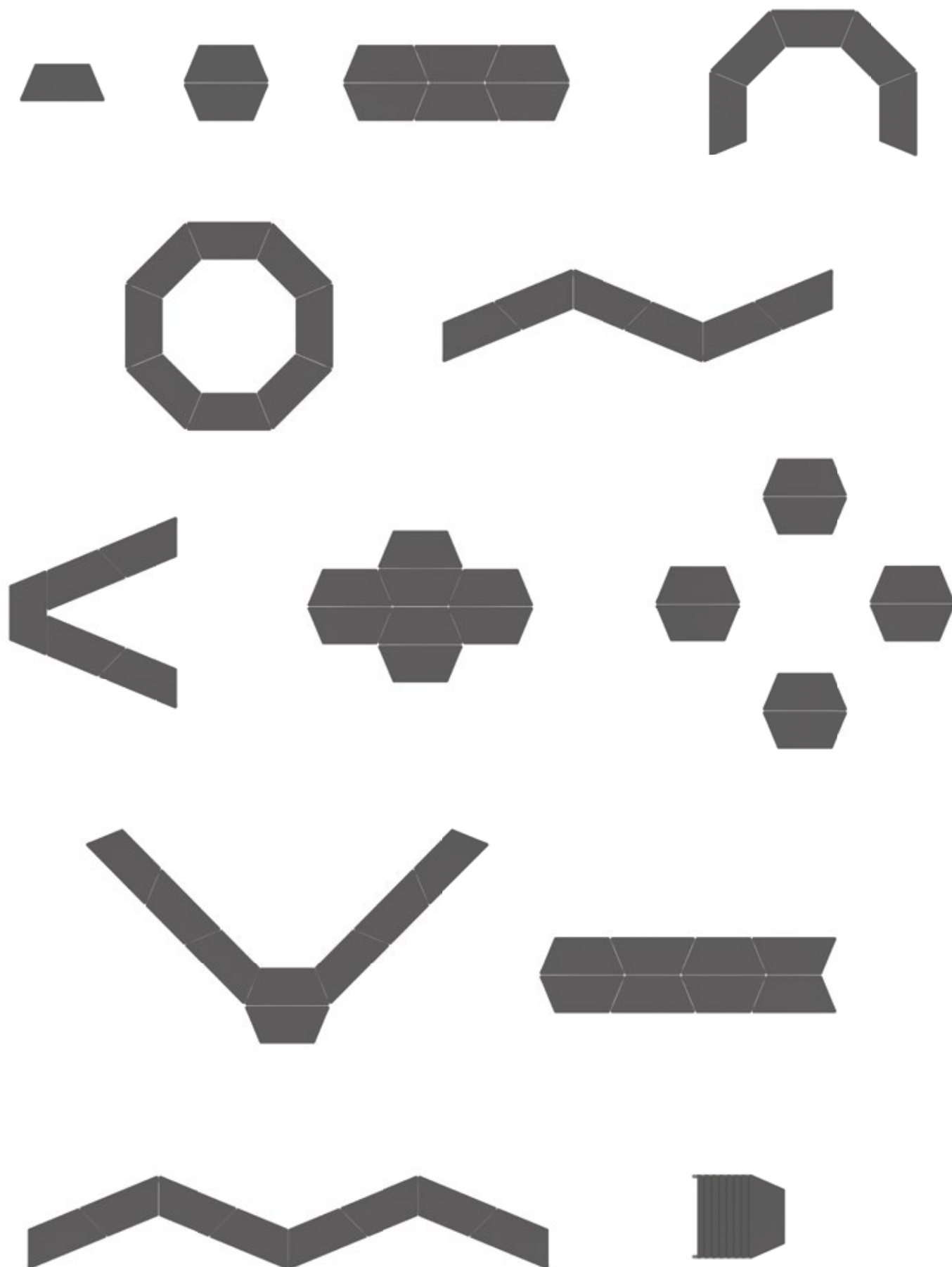

# Scout Meet





# Scout Meet

Konstantin Grcic, 2026



The simple, robust Scout Meet meeting table is also available in standing height as Scout Meet High. It offers space for up to eight people and, as a standing table, features a comfortable footrest. With a cohesive design that complements the rest of the Scout family, it is the ideal addition to environments already containing other versions of the Scout desk.

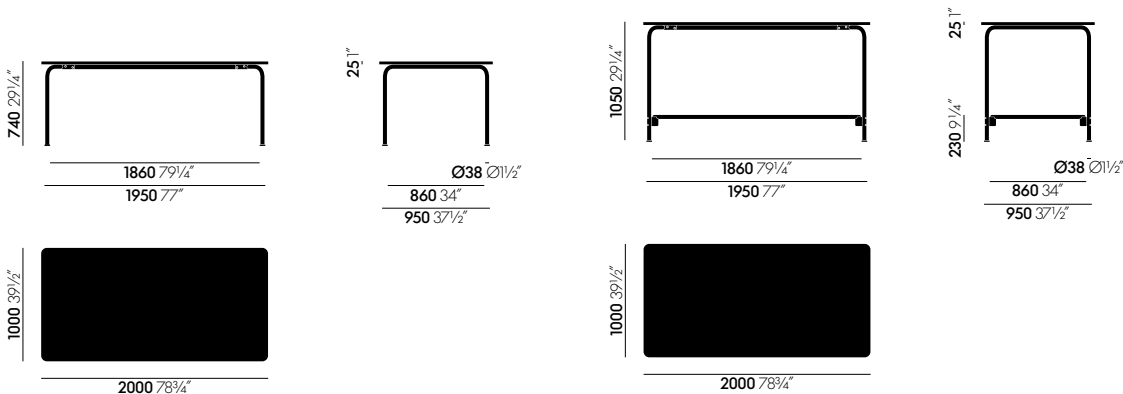

Scout Meet

Scout Meet High



## Surface finishes



Base soft light, table top melamine white



Base soft light, table top birch veneer, natural



Base basic dark, table top deep black, anti-fingerprint coating



Base basic dark, table top birch veneer, natural



Scout Meet can be outfitted with Doppio for integrated power connections.



## **Doppio**

Doppio is a cable flap made of powder-coated aluminium (recycled content up to 95%). The dual-access flap opens from both sides, making it an ideal solution for meeting tables. The table top remains free of bothersome cabling, while sockets are hidden from view and excess cable is stored in cable baskets. When the flap is closed, cables can be routed through the slit to the desktop. The flap is equipped with a soft-close mechanism and can be removed entirely to allow full access to the electrification.



## Doppio cable basket

Cable basket made of steel wire with a diameter of 4 mm, powder-coated in deep black. Cable baskets are suspended between two rails and hooked into place without the use of any tools. The sheet steel rails with a powder-coated finish in deep black are screwed directly to the table top. Sockets are secured in the cable basket using hook-and-eye fasteners.

Dimensions H 78 x W 440 x D 284 mm.



## Tens Kit 4 power outlet unit

4-socket power outlet unit made of black plastic and aluminium with a stainless-steel look for direct attachment to cable basket, with a GST18 input and output connection at either end. Feed cables, connecting cables and patch cables must be ordered separately. Unit can be individually configured with sockets for power, RJ45 (2x), HDMI/USB and VGA with 3.5 mm jack. Please note country-specific variations.



## Current Power 4 power outlet unit

4-socket power outlet unit made of black plastic for direct attachment to cable basket, with a GST18 input and output connection at either end. Feed cables and connecting cables must be ordered separately. Unit can be individually configured with sockets for power or USB A/C chargers (rated power output A: 18 watts, C: 18 watts and combined: 15 watts). Please note country-specific variations.



Scout Meet and Scout Meet High are extremely versatile



2 Scout Meet tables form a 2 x 2 m meeting table for up to 10 people



2 Scout Meet High tables form a long standing-height meeting table, for use with a high chair or as a standing-only table – thanks to the practical footrest around the perimeter

# Scout Meet





Ultraviolet



Ready?



Soft Grey





Lifelong Learning

Neon yellow





Nothing hidden,  
Nothing  
wasted.

Soft Grey



Place to  
belong,  
space to come  
together

# Tangerine





Deep Black







## Vitra Test Centre

All Vitra office chairs are subjected to rigorous testing, based on the parameters of 15 years of use, at the company's own Test Centre. Vitra carries out tests that go far beyond standard requirements, with an

inspection catalogue comprised of the world's toughest tests (simulation of worst-case usage).

Over the years, Vitra has developed additional tests of its own that are not found in any official catalogue of standards.



## Greenguard

The GREENGUARD label for indoor air quality (2001) recognises products that contribute to the creation of healthier indoor environments.



## GS

With the GS seal for tested safety, a state-authorised inspection institute certifies the suitability and safety of the construction and monitors production at regular intervals.

DIN EN 15372 (Scout Sprint, Summit, Work und Work Mobile) / DIN EN 527-2 (Scout Meet)

## BIFMA

## Bifma

Scout fulfils the ANSI/BIFMA standard X5.5-2021, thus meeting the stringent safety requirements for the US market.

# Colours and materials



**52**  
soft light  
powder-coated  
(textured)

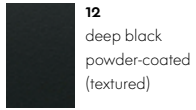

**12**  
deep black  
powder-coated  
(textured)

**Frame**

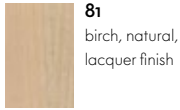

**81**  
birch, natural,  
lacquer finish

**Table top veneer  
(Scout Meet,  
Scout Work, Scout  
Work Mobile)**



**52**  
soft light (tex-  
tured)

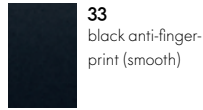

**33**  
black anti-finger-  
print (smooth)

**Table top  
melamine**



**01**  
pebble grey



**01**  
pebble grey



**03**  
grey melange



**03**  
grey melange

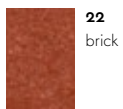

**22**  
brick

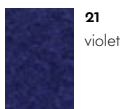

**21**  
violet

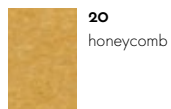

**20**  
honeycomb

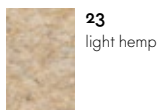

**23**  
light hemp



**22**  
brick

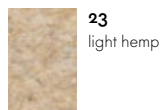

**23**  
light hemp

**Screens and pinboard  
(Scout Work, Scout  
Work Mobile)**

**Screens (Scout Sprint)**



**53**  
soft grey  
powder-coated  
(textured)



**66**  
ultraviolet  
powder-coated  
(textured)

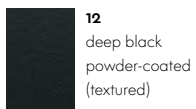

**12**  
deep black  
powder-coated  
(textured)

**Belt handle and belt**



**61**  
neon yellow  
powder-coated  
(textured)



**27**  
tangerine  
powder-coated  
(textured)



**53**  
soft grey RE

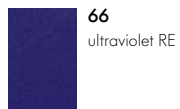

**66**  
ultraviolet RE



**12**  
deep black RE

**Accessories**



**60**  
neon yellow RE



**27**  
tangerine RE

# Dimensions

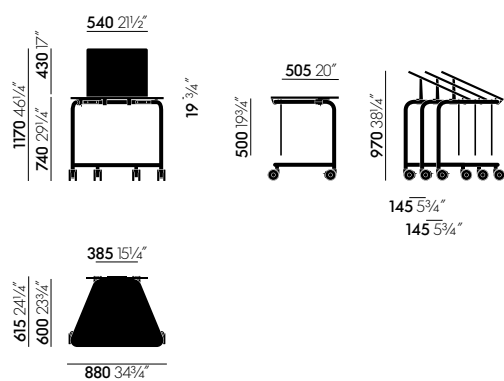

## Scout Sprint

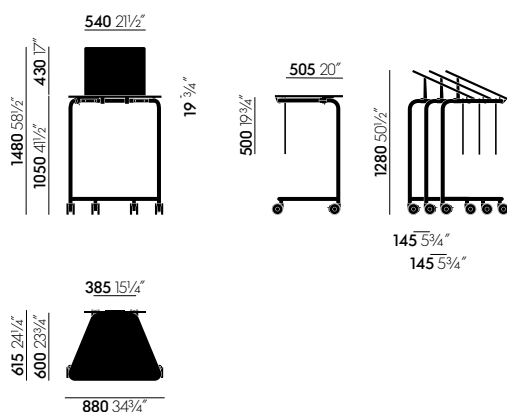

## Scout Sprint High

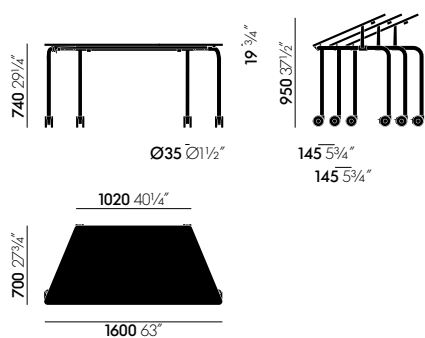

## Scout Summit

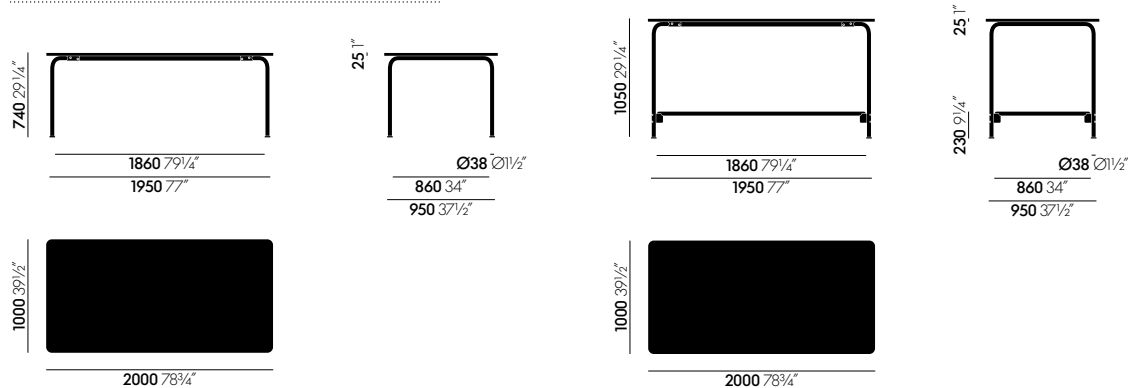

## Scout Meet

## Scout Meet High

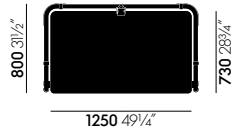
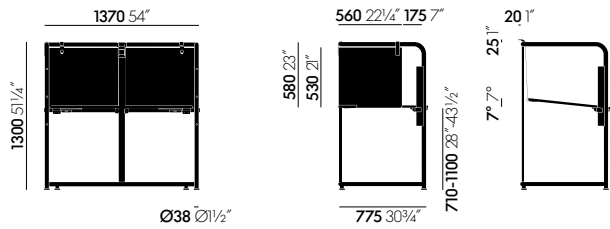

Scout Work

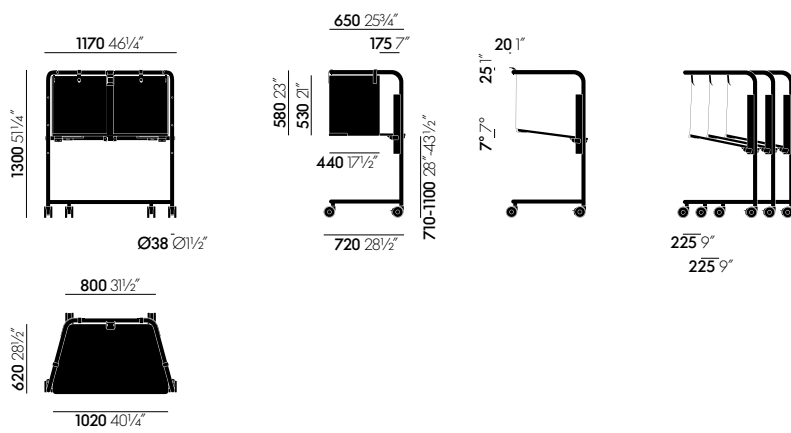

Scout Work Mobile

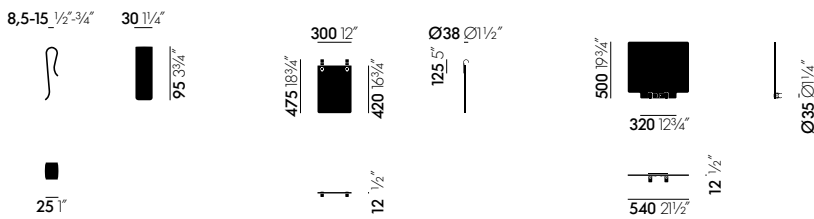

Scout, clip for screen

Scout, pinboard for Scout Work and Work Mobile

Scout, screen for Scout Sprint and Sprint High

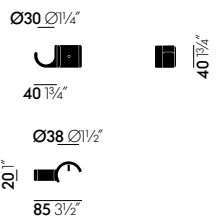

Scout, side hook for Scout Work and Work Mobile

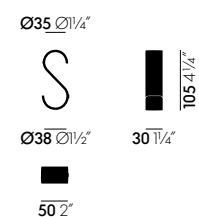

Scout, S-hook